

Stabilita alternatoru

Description

Jednoduchy model stability alternatoru.

Vznik poruchy na vazebnim dvojbranu a posleze jeji vypnuti.

Nedokonale respektovan dej po vzniku poruchy, protoze je brano v uvahu E za X_d nikoli E' za X_d'
Neuvazovan vliv regulace buzeni.

System Parameters

$P_{max1} = 61.489$	[MW]	Maximum cinneho vykonu alternatoru pred poruchou
$P_{max2} = 2.2907$	[MW]	Maximum cinneho vykonu alternatoru behem poruchy
$P_{max3} = 61.378$	[MW]	Maximum cinneho vykonu alternatoru po poruse
$P_t = 40$	[MW]	Mechanicky vykon turbiny
$T_{por} = 1$	[s]	Doba vzniku poruchy
$T_{vyp} = 1.15$	[s]	Doba vypnuti poruchy
$\omega_S = 2 \cdot \pi \cdot 50$	[rad/s]	Uhlova synchronni rychlost soustroji
$T_m = 7$	[s]	Mechanicka casova konstanta
$K_{tlum} = 5000$	[N.m.s/rad]	Konstanta tlumeni soustroji

Model

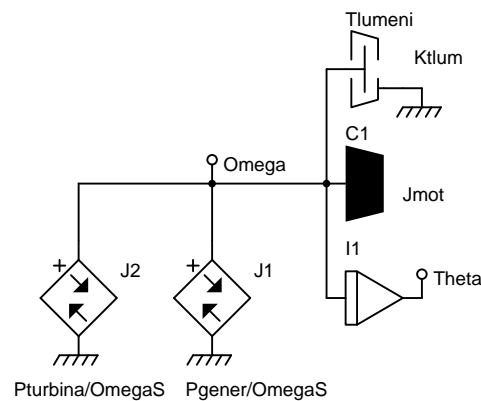

Data

*: Stabilita alternatoru

*SYSTEM;

Pmax1=61.489; :: [MW] Maximum cinneho vykonu alternatoru pred poruchou

Pmax2=2.2907; :: [MW] Maximum cinneho vykonu alternatoru behem poruchy

Pmax3=61.378; :: [MW] Maximum cinneho vykonu alternatoru po poruse

Pt=40; :: [MW] Mechanicky vykon turbiny

Tpor=1; :: [s] Doba vzniku poruchy

```

Tvyp=1.15;           :: [s] Doba vypnuti poruchy
Pgener=1e6*sin(Theta)*
  (Pmax1*(TIME<Tpor)
  +Pmax2*(TIME>=Tpor)*(TIME<Tvyp)
  +Pmax3*(TIME>=Tvyp));
Pturbina=-Pt*1e6;

OmegaS=2pi*50;      :: [rad/s] Uhlova synchronni rychlost soustroji
Tm=7;               :: [s] Mechanicka casova konstanta
Jmot=Tm*40e6/OmegaS**2; :: [m^2*kg/rad] Moment setrvacnosti soustroji
Ktlum=5000;        :: [N*m*s/rad] Konstanta tlumeni soustroji

J1 Omega = Pgener/OmegaS;
J2 Omega = Pturbina/OmegaS;
C1 Omega = Jmot;
I1 > @Int Omega,Theta;
Tlumeni > G Omega = Ktlum;

*TR;
TR 0 5;
PRINT(3001) Omega, Theta, Pgener,Pturbina;
INIT Theta=0.70827, Omega=0;
RUN;
*END;
::Theta [rad] Zatezny uhel
::Omega [rad/s] Rozdilova uhlova rychlost soustroji proti synchronni
::Pgener [W] Cinny elektricky vykon alternatoru
::Pturbina [W] Mechanicky vykon turbiny

```

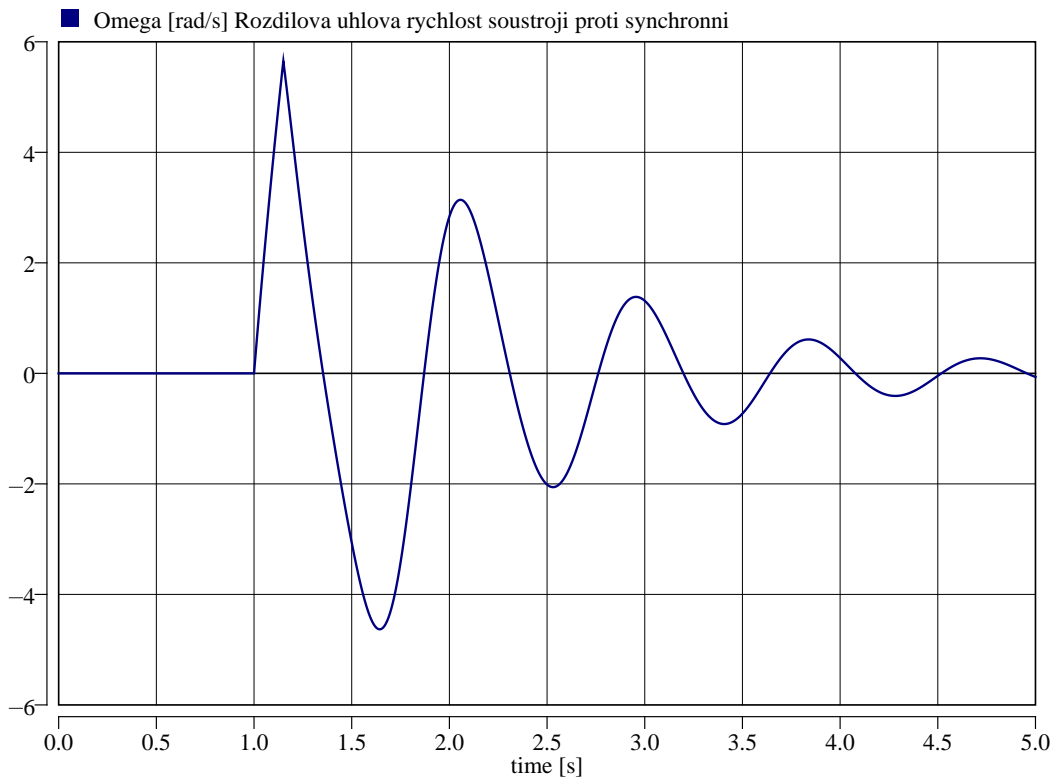

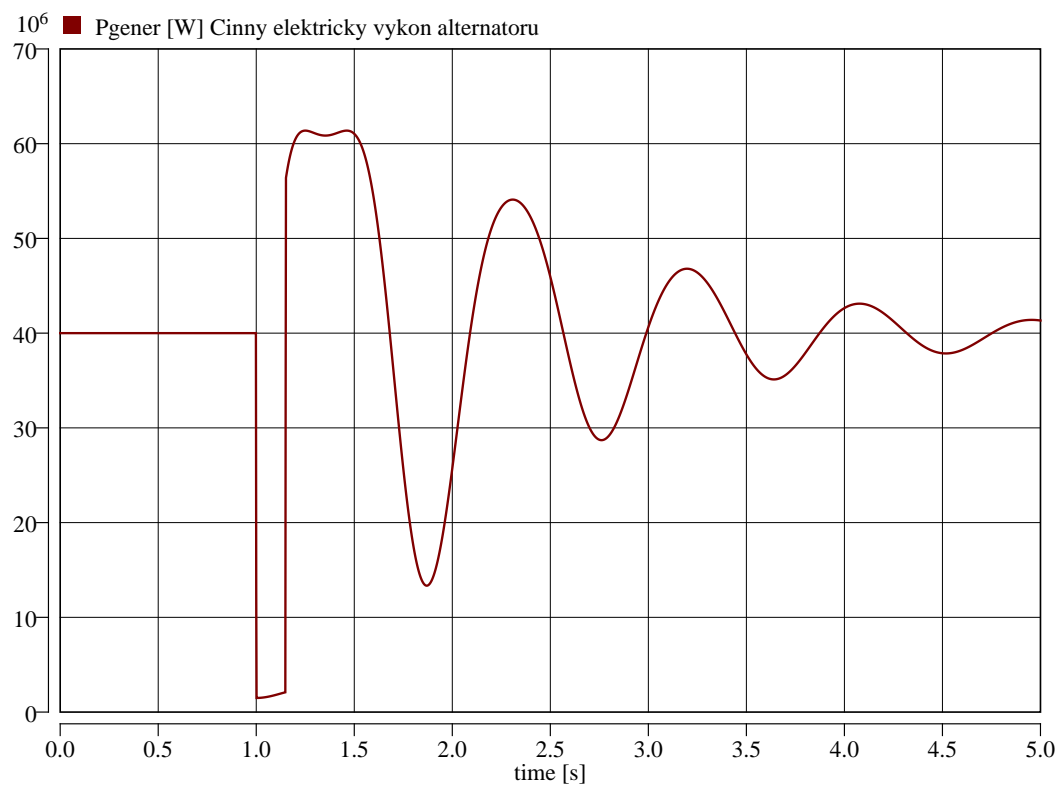
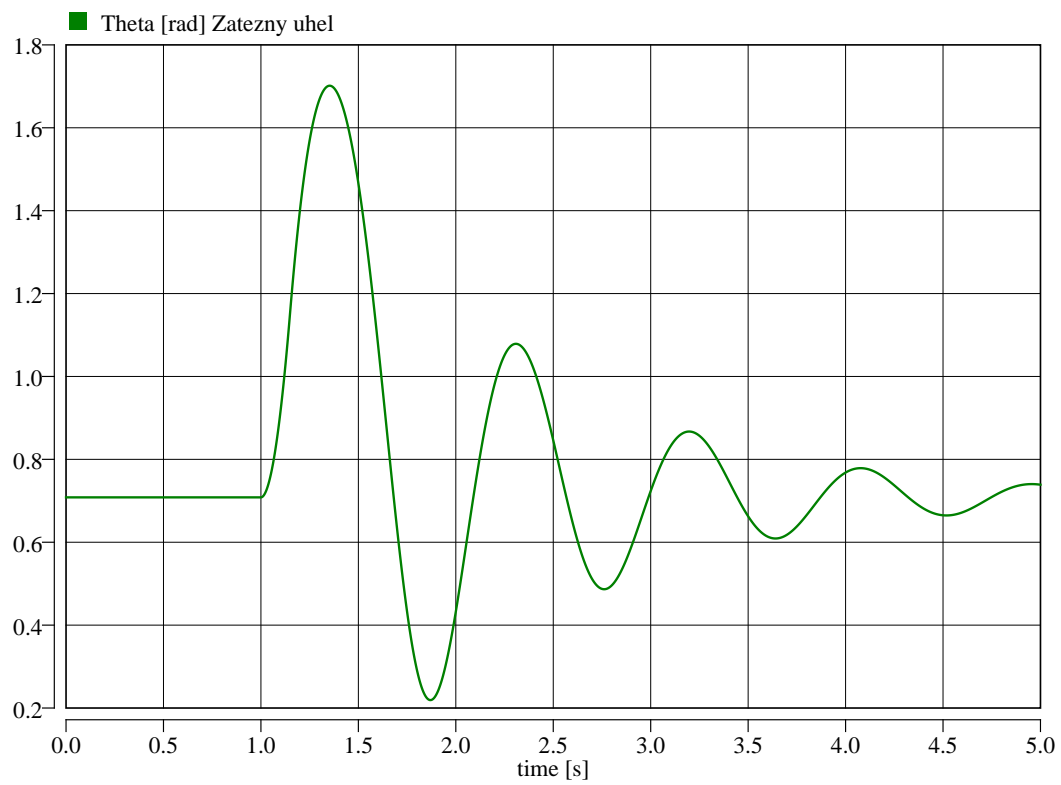

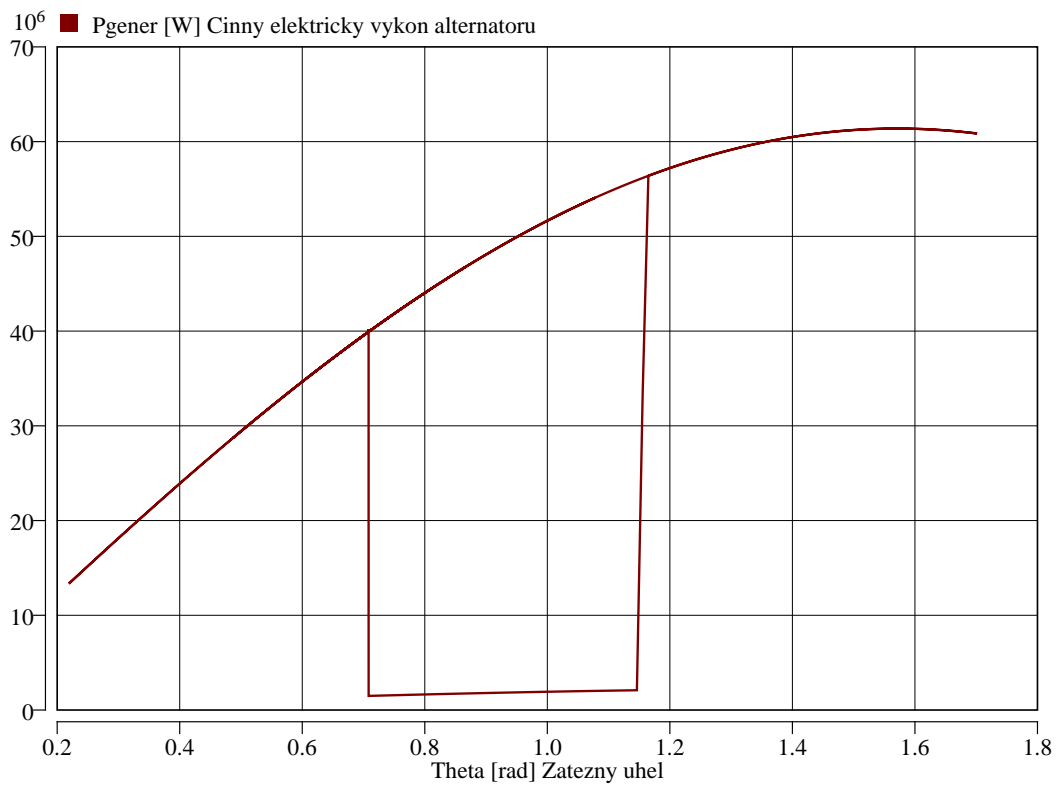

Origin

Karel Nohá KEE, FEL, Z U v Plzni

Last Update

December 16, 2015